

Safety Precautions

Read all safety precautions and installation instructions carefully before installing or servicing this fixture. Failure to comply with these instructions could result in potentially fatal electric shock and/or property damage.

It is recommended that a qualified electrician perform all wiring. This fixture must be wired in accordance with all national and local electrical codes.

Do not handle any energized fixture or attempt to energize any fixture with wet hands or while standing on a wet or damp surface or in water.

This fixture is designed for use in a 110-120VAC, 60Hz fused circuit and can be used in conjunction with *most* 2-wire, triac dimmers.

To reduce the risk of electrical shock, and to assure proper operation, this fixture must be adequately grounded. To accomplish proper grounding, there must be a separate ground wire (green) contact between this fixture and the ground connection of your main power supply panel.

This fixture is intended to be used for general indoor lighting in dry or damp locations only.

ASSEMBLY INSTRUCTIONS

Step 1 - Preparing for installation.

A. **Disconnect electrical power** at fuse or circuit breaker box before installing or servicing any part of this fixture.

B. Carefully remove the fixture from the carton.

Step 2 - Remove circular gem bar (1) from the fixture base by removing two screws (3).

Wiring-all wiring must take place inside junction box (not included).

Caution: Make sure power is off at fuse or circuit breaker box. Check power wires for damage or scrapes. If power supply wires are within three inches of the ballast power supply, use wire suitable for at least 90°C (194°F).

Note: Most dwellings built before 1985 have supply wire rated to 60C. Consult a qualified electrician before installing.

Step 3 - Install circular gem bar (1) on the junction box (not provided) by securing it with two screws (2).

Step 4 – Wiring fixture.

A. Make all wire connections to appropriate wire. Secure with wire nuts (provided).

B. Connect the green wire from the fixture to the supply power source ground wire.

C. The black wire from the fixture is connected to the black (Hot) wire from supply power source.

D. The white wire from the fixture is connected to the white (Common) wire from supply power source.

E. Tuck all connections neatly into the junction box.

Step 5 - Place fixture base (4) over the gem bar, align two mounting holes on both sides.

Step 6 - Install fixture by securing the base with two screws (3).

Step 7 - Restore power at fuse or circuit breaker box.

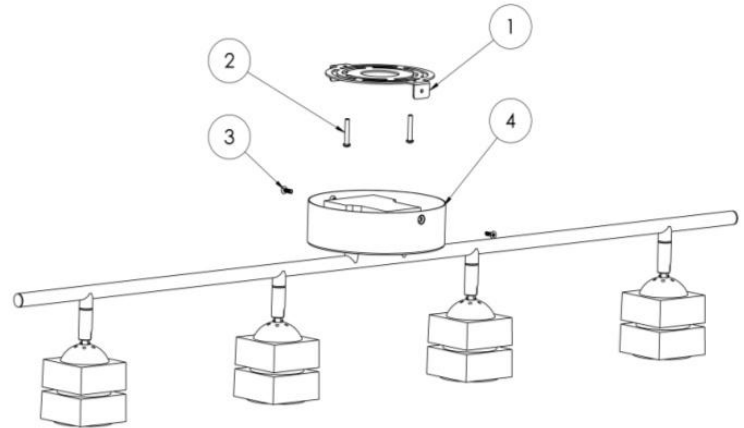

Luminous Intensity Distribution

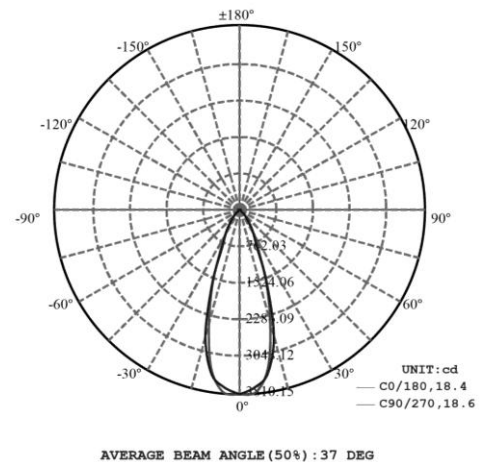

REPLACING THE LED DRIVER

IMPORTANT! Do NOT disassemble product. This operation is only for the replacement of a faulty LED Driver.

IMPORTANT! It is recommended that the replacement of an LED driver be completed by a qualified electrician.

CAUTION! Turn off main power at fuse or circuit breaker box.

Disassembly:

1. Remove fixture from wall by removing (2) canopy screws
2. Disconnect LED driver power wires from power supply wires in junction box by removing wire nuts.
3. Separate LED driver from canopy by removing (2) screws.
4. Disconnect (2) driver wires from fixture wires.

NOTE: Mark fixture wires with tape to match black wire with parallel fixture head wires on one side, and red wire with parallel fixture head wires on the other side
Discard driver.

Re-assembly

1. Using new LED driver, connect red and black wires to matching parallel fixture head wires with wire nuts.
2. Re-attach driver to canopy with 2 screws.
3. Connect power supply wires from drive to power supply wires from junction box.
4. Connect black wire to black wire, white to white and ground (Copper) to ground (Green or copper)
5. Tuck supply wires in junction box.
6. Connect canopy to junction box/gem bar with (2) screws
7. Restore power to the fixture.

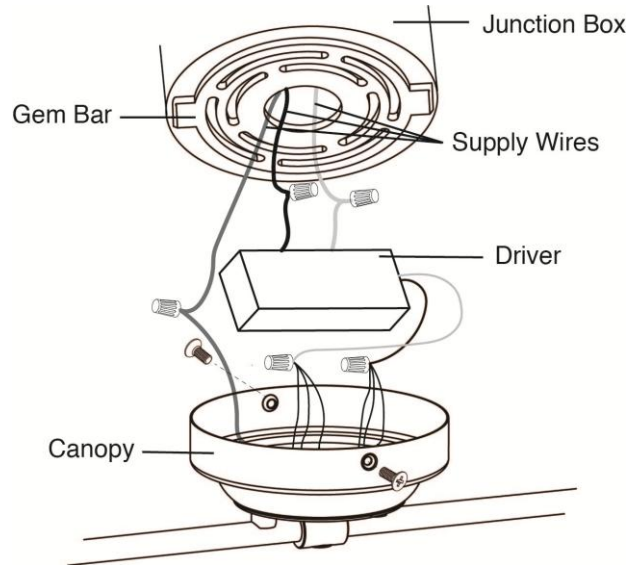

DIMMER COMPATIBILITY

Product can be dimmed down to 10% of full scale using a standard two-wire dimmer.

Brand	Series	Model#	Brand	Series	Model#
Lutron®	Maestro	MACL-153M	Leviton®	Decora	DLS06-1LZ
	Skylark Contour	CTCL-153P		Illuma Tech	IPL06-10Z
	Caseta	PD-6WCL		Sure Slide	6672-1LW
				Sure Slide	6674-P0W

Limited Factory Warranty

AFX warrants this fixture is free from defects in materials and workmanship when installed and used under normal operating conditions for a period of 5 years from date of purchase. This warranty covers all component parts and extends only to replacement of defective fixture or components; it does not cover failure due to improper installation, misuse, mishandling or damage incurred in transit